

Overview

Size (mm)

Panel Size (mm)	479 x 479 479 x 1546
-----------------	-------------------------

Panel Depth	50mm Thickness
-------------	----------------

COLORBOND® Options	Surfmist White
--------------------	----------------

Fixing/Installation	Pre-drilled holes with screws to fix to RHS welded frame
---------------------	--

Container Wall Air Relief Grille

Wall Air relief grilles are typically used to help maintain heat discharge in areas where constant air transfer is required. Our grilles can be fixed or welded into the side of your converted shipping container.

Ventilation in containers is typically used in portable plant containers, boiler houses, shipping container welfare and toilets blocks.

Steel welded box section frames are required to weld the louvre within.



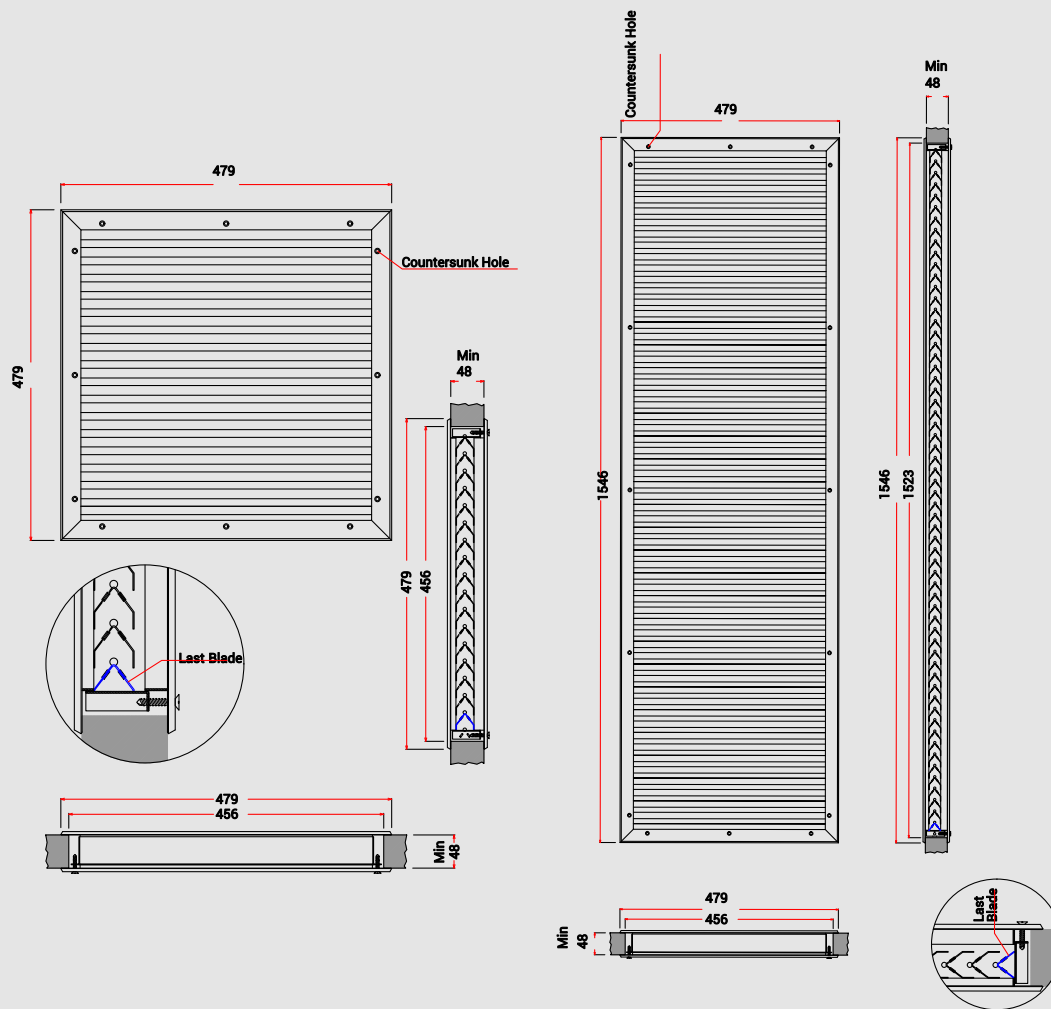

Steel welded box section frames are required to weld the louvre within.

- Fixed blade design
- Up to 50% air flow
- 50mm Depth
- Steel construction
- Powder coated white (suitable for painting)

Steel Louvre Panel Drawing

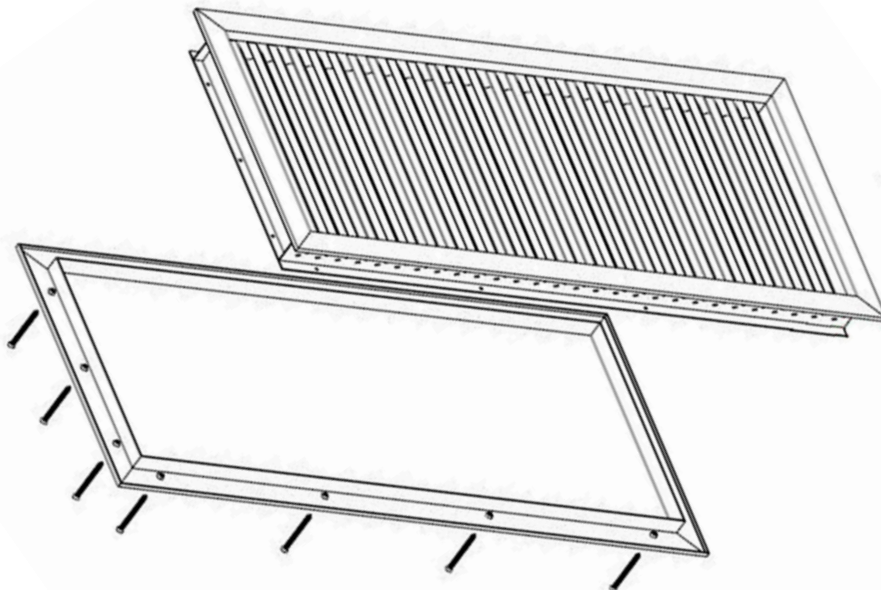

For more information please visit our website:
www.lathamsteeldoors.com.au or give us a call on +61 415 310 911